

# KOMATSU®

## HD405-7

### With Tier 3 Engine

**GROSS HORSEPOWER**

386 kW 518 HP

**NET HORSEPOWER**

371 kW 498 HP

**MAXIMUM GVW**

75080 kg 165,520 lb

**HD  
405**

OFF-HIGHWAY TRUCK



Photo may include optional equipment

# WALK-AROUND

## *Productivity Features*

- High performance Komatsu SAA6D140E-5 engine  
Net horsepower 371 kW **498 HP**
- Variable horsepower system
- Automatic Idling Setting System (AISS)
- 7-speed, fully automatic K-ATOMiCS transmission
- Fully hydraulic controlled wet multiple-disc brakes and retarder; Retarder absorbing capacity (Continuous descent) 662 kW **887 HP**
- Long wheelbase and wide tread
- Large high strength body  
Heaped capacity 27.3 m<sup>3</sup> **35.7 yd<sup>3</sup>**
- Tight turning radius 7.2 m **23'7"**
- Automatic Retard Speed Control (ARSC) (Option)

## *Environment Friendly*

- Komatsu SAA6D140E-5 engine is North American EPA Tier 3 and EU Stage 3A emission certified for 2006
- Low noise levels
- Lead-free radiator
- Brake cooling oil recovery tank

## *Reliability Features*

- Komatsu designed components
- Box-section frames
- Rugged and durable dump body design
- Reliable hydraulic system
- Sealed DT electrical connectors
- Pedal-operated secondary brake
- Antilock Brake System (ABS) (Option)
- Automatic Spin Regulator (ASR) (Option)



## **KOMTRAX™**

KOMTRAX equipped machines can send location, SMR and operation maps to a secure website utilizing wireless technology. Machines also relay error codes, cautions, maintenance items, fuel levels, and much more.

**GROSS HORSEPOWER**  
386 kW 518 HP @ 2000 rpm

**NET HORSEPOWER**  
371 kW 498 HP @ 2000 rpm

**MAXIMUM GVW**  
75080 kg 165,520 lb

### ***Operator Environment***

- Wide, spacious cab with excellent visibility
- Ergonomically designed cab
- Easy-to-see instrument panel
- Tilttable, telescoping steering wheel and low effort pedals
- K-ATOMiCS with "Skip-Shift" function
- Hydropneumatic suspension
- Built-in ROPS/FOPS
- Viscous cab mounts
- Electric body dump control lever
- Supplementary steering and secondary brakes
- Air suspension seat (Option)



### ***Easy Maintenance***

- Advanced monitoring system-onboard diagnostics
- Wet multiple-disc brakes and fully hydraulic braking system
- Extended oil change interval
- Centralized arrangement of filters
- Flange type tire rims
- Electric circuit breaker
- Centralized greasing points
- KOMTRAX

Photo may include optional equipment

**GALEO**

Komatsu's highly productive, innovative technology, environmentally friendly machines built for the 21st century.

## PRODUCTIVITY FEATURES

### Komatsu Technology



Komatsu's new "ecot3" engines are designed to deliver optimum performance under the toughest of conditions while meeting the latest environmental regulations. This engine is Tier 3 EPA, EU Stage 3A and Japan emissions certified. "ecot3" – ecology and economy combined with Komatsu technology to create a high performance engine without sacrificing power or productivity.

### High performance Komatsu SAA6D140E-5 engine

This engine delivers faster acceleration and higher travel speeds with high horsepower per ton. Advanced technology, such as Common Rail Injection system (CRI), air-to-air aftercooler, efficient turbo-charger, and heavy-duty cooled EGR enables the engine to be North American EPA Tier 3 and EU stage 3A emission certified. High torque at low speed, impressive acceleration, and low fuel consumption ensure maximum productivity.

### Mode selection system

The system allows selection of the appropriate mode between <Power mode > or <Economy mode> according to each working condition. The mode is easily selected with a switch in the operator's cab.

### Power mode

Greater productivity can be attained by taking full advantage of high output power. This mode is appropriate for job sites where higher production and uphill-hauling are required.

### Economy mode (variable horsepower)

The engine power automatically changes depending on loaded or unloaded conditions and always uses an optimum gear speed. It is appropriate for lighter load factors on flat ground.

### Automatic Idling Setting System (AISS)

This system facilitates quick engine warm-up and cab cooling/warming. When setting the system ON, engine idle speed is kept at 945 rpm when coolant temperature is 50°C 122°F or lower. Speed automatically returns to 725 rpm when coolant temperature reaches 50°C 122°F.



### 7-speed, fully automatic K-ATOMiCS transmission

The K-ATOMiCS (Komatsu Advanced Transmission with Optimum Modulation Control System) automatically selects the optimum gear according to vehicle speed, engine speed and the shift position you've chosen. This results in the best gear for any operating condition.



K-ATOMiCS (Komatsu Advanced Transmission with Optimum Modulation Control System)

### Automatic Retard Speed Control (ARSC)(Option)

ARSC allows the operator to simply set the downhill travel speed and go down slopes at a constant speed. As a result, the operator can concentrate on steering. The speed can be set at increments of 1 km/h 0.6 MPH per click (±5 km/h 3.1 MPH of maximum speed adjustment) to match the optimum speed for the slope. Also, since the retarder cooling oil temperature is always monitored, the speed is automatically lowered if the retarder oil temperature rises.



### Fully hydraulic controlled wet multiple-disc brakes and retarder

Wet multiple-disc brakes ensure highly reliable and stable brake performance. The large-capacity, continuously cooled, wet multiple-disc brakes also function as a highly responsive retarder which gives the operator greater confidence at higher speeds when travelling downhill.

- Retarder Absorbing Capacity (continuous descent): 662 kW **887 HP**
- Brake Surface Area (rear): 50847 cm<sup>2</sup> **7,881 in<sup>2</sup>**

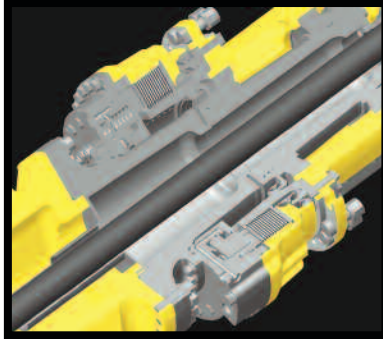

### Small turning radius

The MacPherson strut type front suspension has a special A-frame between each wheel and the main frame. The wider space created between the front wheels and the main frame increases the turning angle of the wheels. The larger the wheel turning angle, the smaller the turning radius of the truck.

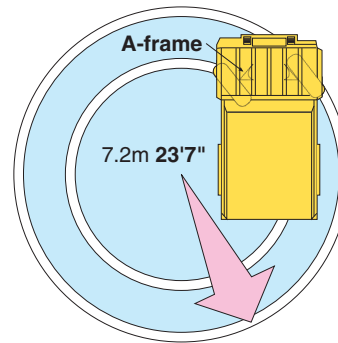

### Long wheelbase and wide tread

With an extra-long wheelbase, a wide tread and an exceptionally low center of gravity, the HD405-7 hauls the load at higher speed for more production, and delivers superior driving comfort over rough terrain.

### Large high strength body

A wide target area makes for easy loading with minimal soil spillage and more efficient hauling. The body is built of 160 kg/mm<sup>2</sup> **227,520 PSI** wear-resistant high-tensile steel with a Brinell hardness of 500. The V-shape design also increases structural strength and provides excellent load stability.



# OPERATOR ENVIRONMENT

### Wide, spacious cab with excellent visibility

Wide windows in the front, side and back, plus plenty of space in the richly upholstered interior, provide quiet, comfortable environment from which to see and control every aspect of operation. Front and side under view mirrors have been added to improve safety.

### Ergonomically designed cab

The ergonomically designed operator's compartment makes it very easy and comfortable for the operator to use all the controls. The result is more confident operation and greater productivity.

### Easy-to-see instrument panel

The instrument panel makes it easy to monitor critical machine functions. In addition, a caution light warns the operator of any problems that may occur. Problems are recorded in the monitor and indicated as service codes. These onboard diagnostics make the machine user-friendly and easy to service.

### Optimum operator seat position

The 5-way adjustable operator seat and the tilt-telescopic steering column create an optimum operating posture for increased operating comfort and more control over the machine's operations. The suspension seat dampens vibrations transmitted from the machine, which reduces operator fatigue and holds the operator securely to assure confident operation. 78 mm 3" width seat belt is provided as standard equipment.



### Hydropneumatic suspension for all terrain

The hydropneumatic suspension assures a comfortable ride even over rough terrain and ensures maximum productivity and operator confidence.

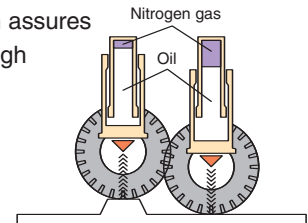

**K-ATOMiCS with “Skip-shift” function**

An electronically controlled valve is provided for each clutch pack in the transmission for independent clutch engagement/disengagement. It enables an ideal change in clutch modulation pressure and torque cut-off timing in response to travel conditions. This system plus the “skip-shift” function ensure smooth shifting and responsive acceleration.

**“Skip-shift” function**

Optimum travel speed is automatically selected in response to the angle of ascent. Reduced frequency of downshift and smoother operation improves operator comfort and truck reliability.

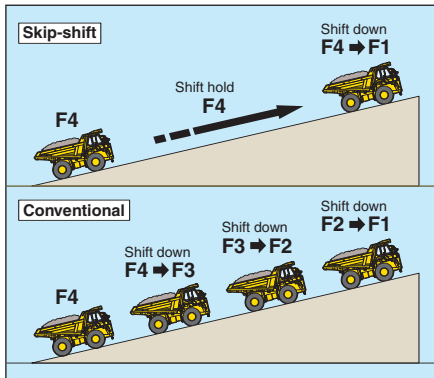

**Built-in ROPS/FOPS**

These structures conform to ISO3471 and SAE J1040 ROPS standards, and ISO 3449 and SAE J231 FOPS standards.



**Viscous cab mounts**

Viscous mounts reduce the noise transmitted to the cab and achieve a quiet 77 dB(A) noise level.

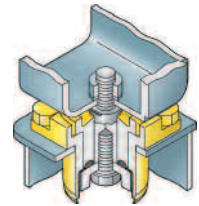

**Electric body dump control lever**

The low effort lever makes dumping easy. A positioning sensor is installed for dump body control which significantly reduces the shock made by the lowering of the dump body.



**Supplementary steering and secondary brakes**

Supplementary steering and secondary brakes are standard features.

Steering: ISO 5010, SAE J1511, SAE J53

Brakes: ISO 3450, SAE J1473



# RELIABILITY FEATURES

## Komatsu components

Komatsu manufactures the engine, torque converter, transmission, hydraulic units, and electrical parts on this dump truck. Komatsu dump trucks are manufactured with an integrated production system under a strict quality control system.

## Box-section frames

Cast-steel components are used in the box section main frame for high-stress areas where loads and shocks are most concentrated.

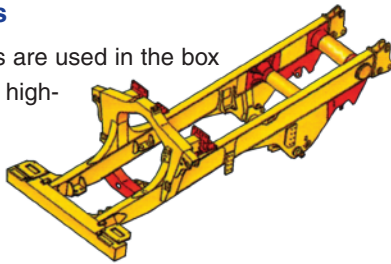

## Rugged and durable dump body design

The standard dump body is made of a high-tensile-strength steel for excellent rigidity and reduced maintenance cost.

The V-shape design also increases structural strength. The side and bottom plates of the dump section are reinforced with ribs for added strength.

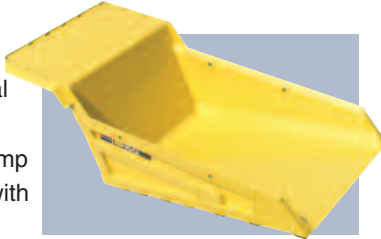

## Reliable hydraulic system

The oil cooler is installed in the radiator lower tank, improving the reliability of the hydraulic system during sudden temperature rises. In addition to the main filter, a 25-micron line filter is installed at the entrance to the transmission control valve. This system helps to extend the valve and transmission life.

## Flat face-to-face O-ring seals

Flat face-to-face O-ring seals are used to securely seal all hydraulic hose connections to prevent oil leakage.

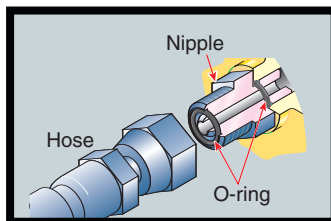

## Sealed DT electrical connectors

Main harnesses and controller connectors are equipped with sealed DT connectors providing high reliability, water resistance, and dust resistance.



## Antilock braking system (ABS) (Option)

Using its outstanding electronics technology, Komatsu is the first in the industry to introduce ABS on construction machinery. This system prevents the tires from locking, thus minimizing skidding under slippery conditions while applying the service brake.

## Automatic spin regulator (ASR) (Option)

ASR automatically prevents the rear tires, on either side, from slipping on soft ground for optimal traction.

## Pedal-operated secondary brake

If there should be a failure in the foot brake, the parking brake and front disc brakes are activated as pedal operated secondary brake. In addition, when hydraulic pressure drops below the rated level, the parking brake is automatically actuated.



## Lead-free radiator

In addition to compliance with emission regulations, a lead-free aluminum core is utilized for the radiator to comply with global environmental requirements.

## Brake cooling oil recovery tank

To protect the environment, a tank is installed to recover brake cooling oil in the event of brake seal leakage.

## Protection functions supported by electronic control

Item	Function
<b>Downshift inhibitor</b>	Even if the driver downshifts accidentally, a speed appropriate to the current gear is automatically set, preventing over-runs.
<b>Over-run inhibitor</b>	When descending grades, if vehicle's speed surpasses maximum for current gear, rear brakes automatically operate, preventing over-runs.
<b>Reverse inhibitor</b>	The vehicle is prevented from moving backward when operating the body.
<b>Forward/Reverse shift inhibitor</b>	This device makes it impossible to shift from forward to reverse when the vehicle's speed surpasses 4 km/hr <b>2.5 mph</b> .
<b>Anti-hunting system</b>	When running near a shift point, a smooth automatic shifting takes place.
<b>Neutral safety</b>	The engine is prevented from starting when the shift lever is not in neutral.



# EASY MAINTENANCE

### Advanced monitoring system

The Komatsu advanced onboard diagnostic system identifies maintenance items, reduces diagnostic times, indicates oil and filter replacement hours and displays abnormality codes. This monitor system helps to maximize machine production time.



### Wet multi-disc brakes and fully hydraulic braking systems

mean lower maintenance costs and higher reliability. Wet disc brakes are fully sealed to keep contaminants out, reducing wear and maintenance. Brakes require no adjustments for wear, resulting in even lower maintenance. Added reliability is designed in the braking system with three independent hydraulic circuits providing hydraulic backup should one of the circuits fail. Fully hydraulic braking systems eliminate the air system so air bleeding is not required and water condensation, that can lead to contamination, corrosion and freezing, is also eliminated.

### Extended oil change intervals

In order to minimize operating costs, oil change intervals have been extended:

- Engine oil: 500 hours
- Hydraulic oil: 4000 hours

### Centralized arrangement of filters

The filters are centralized so that they can be serviced easily.

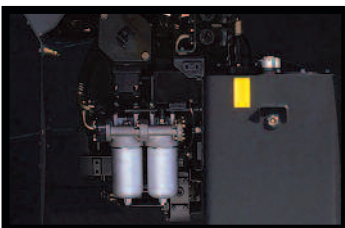

### Flange type tire rim

Flange type rims provide easy removal/installation of tires.



### Electric circuit breakers

A circuit breaker is used in important electric circuits that need to be restored quickly when a problem occurs in the electrical system.



### Centralized greasing points (Option)

Greasing points are centralized at three locations.



## SPECIFICATIONS



### ENGINE

Model . . . . . KOMATSU SAA6D140E-5  
 Type . . . . . Water-cooled, 4-cycle  
 Aspiration . . . . . Turbo-charged, air-to-air after-cooled, cooled EGR  
 Number of cylinders . . . . . 6  
 Bore x stroke . . . . . 140 mm x 165 mm **5.5" x 6.5"**  
 Piston displacement . . . . . 15.24 ltr. **930 in<sup>3</sup>**  
 Horsepower: SAE J1995 . . . . . Gross 386 kW **518 HP**  
 ISO 9249 /SAE J1349 . . . . . Net 371 kW **498 HP**  
 Rated rpm . . . . . 2,000 rpm  
 Fan drive type . . . . . Mechanical  
 Maximum torque . . . . . 2167 N·m 221 kg·m **1600 lb·ft**  
 Fuel system . . . . . Direct injection  
 Governor . . . . . Electronically controlled  
 Lubrication system: Method . . . . . Gear pump, force-lubrication  
 Filter . . . . . Full-flow type  
 Air cleaner . . . . . Dry type with double elements  
 and precleaner, plus dust indicator  
 EPA Tier 3 and EU Stage 3A emission certified.



### TRANSMISSION

Torque converter . . . . . 3-elements, 1-stage, 2-phase  
 Transmission . . . . . Full-automatic, planetary type  
 Speed range . . . . . 7 speeds forward and 1 reverse  
 Lockup clutch . . . . . Wet, single-disc clutch  
 Forward . . . . . Torque converter drive in 1st gear,  
 direct drive in 1st lockup and all higher gears  
 Reverse . . . . . Torque converter drive  
 Shift control . . . . . Electronic shift control with automatic  
 clutch modulation in all gears  
 Maximum travel speed . . . . . 70 km/h **43.5 mph**



### AXLES

Rear axle . . . . . Full-floating  
 Final drive type . . . . . Planetary gear  
 Ratios:  
 Differential . . . . . 3.125  
 Planetary . . . . . 4.737



### SUSPENSION SYSTEM

Independent, hydropneumatic suspension cylinder with fixed throttle to dampen vibration  
 Effective cylinder stroke (front suspension) . . . . . 250 mm **9.8"**  
 Rear axle oscillation:  
 Oil stopper . . . . . 6.8°  
 Mechanical stopper . . . . . 8.1°



### STEERING SYSTEM

Type . . . . . Fully hydraulic power steering  
 with two double-acting cylinder  
 Supplementary steering . . . . . Manual control  
 (meets ISO 5010, SAE J1511 and SAE J53)  
 Minimum turning radius . . . . . 7.2 m **23'7"**  
 Maximum steering angle . . . . . 43°



### CAB

Dimensions comply with ISO 3471 and SAE J1040-1988c ROPS (Roll-Over Protective Structure) standards.



### MAIN FRAME

Type . . . . . Box-sectioned structure



### BRAKES

Brakes meet ISO 3450 and SAE 1473 standards.  
 Service brakes:  
 Front . . . . . Full-hydraulic control, caliper disc type  
 Rear . . . . . Full-hydraulic, oil-cooled, multiple-disc type  
 Parking brake . . . . . Spring applied, caliper disc type  
 Retarder . . . . . Oil-cooled, multiple-disc rear brakes act as retarder  
 Secondary brake . . . . . Manual pedal operation  
 When hydraulic pressure drops below the rated level,  
 parking brake is automatically actuated  
 Brake surface  
 Front . . . . . 968 cm<sup>2</sup> **150 in<sup>2</sup>**  
 Rear . . . . . 50847 cm<sup>2</sup> **7,881 in<sup>2</sup>**



### BODY

Capacity:  
 Struck . . . . . 20 m<sup>3</sup> **26.2 yd<sup>3</sup>**  
 Heaped (2:1 ,SAE) . . . . . 27.3 m<sup>3</sup> **35.7 yd<sup>3</sup>**  
 Payload, maximum . . . . . 41.0 metric tons **45.2 U.S. tons**  
 Material . . . . . 160 kg/mm<sup>2</sup> **227,520 psi**  
 high-tensile-strength steel  
 Structure . . . . . V-shape body  
 Material thickness:  
 Bottom . . . . . 25 mm **0.98"**  
 Front . . . . . 16 mm **0.63"**  
 Sides . . . . . 14 mm **0.55"**  
 Target area  
 (inside length x width) . . . . . 5590 mm x 3380 mm **18'4" x 11'1"**  
 Dumping angle . . . . . 48°  
 Height at full dump . . . . . 7925 mm **26'0"**  
 Heating . . . . . Exhaust heating



### HYDRAULIC SYSTEM

Hoist cylinder . . . . . Twin, 2-stage telescopic type  
 Relief pressure . . . . . 20.6 MPa 210 kg/cm<sup>2</sup> **2,990 psi**  
 Hoist time . . . . . 10 sec



### WEIGHT (APPROXIMATE)

Empty weight . . . . . 34400 kg **75,840 lb**  
 Gross vehicle weight with 41 metric ton  
**45.2 U.S. ton** payload . . . . . 74480 kg **164,200 lb**  
 Max. gross vehicle weight:  
 Standard tire . . . . . 75080 kg **165,520 lb**  
 Not to exceed max. gross vehicle weight, including options, fuel  
 and payload  
 Weight distribution:  
 Empty: Front axle . . . . . 50.7%  
 Rear axle . . . . . 49.3%  
 Loaded: Front axle . . . . . 32.8%  
 Rear axle . . . . . 67.2%



### TIRES

Standard tires . . . . . 18.00 R33



### SERVICE REFILL CAPACITIES

Fuel tank . . . . . 484 ltr. **127.9 U.S. Gal**  
 Engine oil . . . . . 50 ltr. **13.2 U.S. Gal**  
 Torque converter, transmission and  
 retarder cooling . . . . . 90 ltr. **23.8 U.S. Gal**  
 Differential . . . . . 45 ltr. **11.9 U.S. Gal**  
 Final drives (total) . . . . . 30 ltr. **7.9 U.S. Gal**  
 Hydraulic system . . . . . 129 ltr. **34.1 U.S. Gal**  
 Suspension (total) . . . . . 44.2 ltr. **11.7 U.S. Gal**

## DIMENSIONS

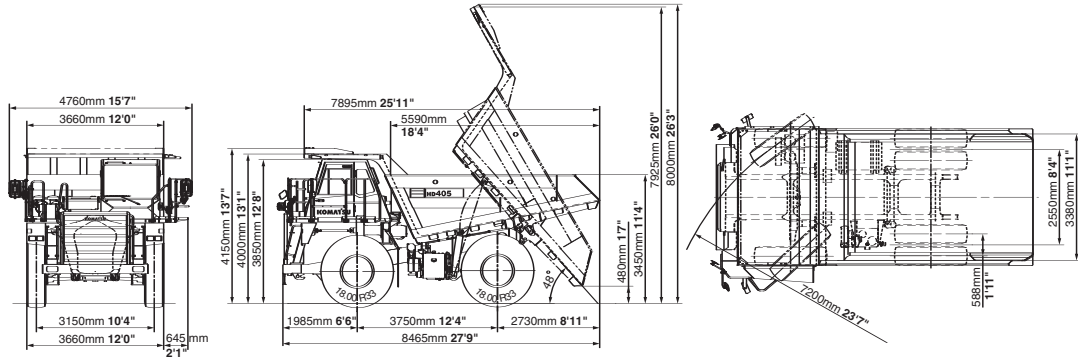

## TRAVEL PERFORMANCE

To determine travel performance:  
 Read from gross weight down to the percent of total resistance. From this weight-resistance point, read horizontally to the curve with the highest obtainable speed range, then down to maximum speed. Usable rimpull depends upon traction available and weight on drive wheels.

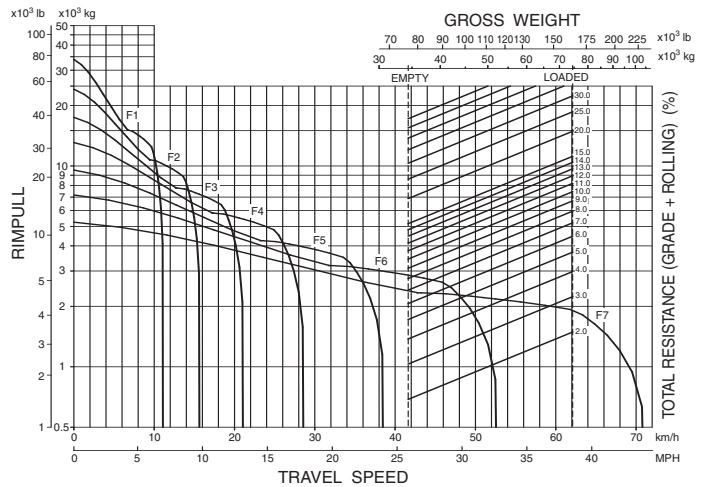

## BRAKE PERFORMANCE

To determine brake performance:  
 These curves are provided to establish the maximum speed and gearshift position for safer descents on roads with a given distance. Read from gross weight down to the percent of total resistance. From this weight-resistance point, read horizontally to the curve with the highest obtainable descent speed the brakes can safely handle without exceeding cooling capacity.

Grade distance: Continuous descent

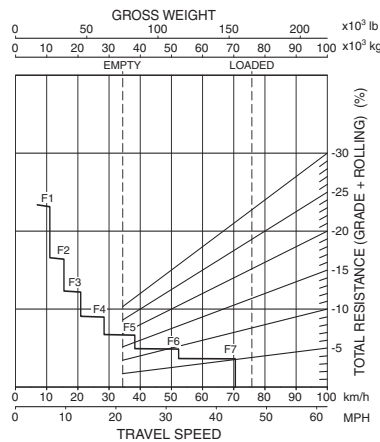

Grade distance: 450 m (1480 ft)

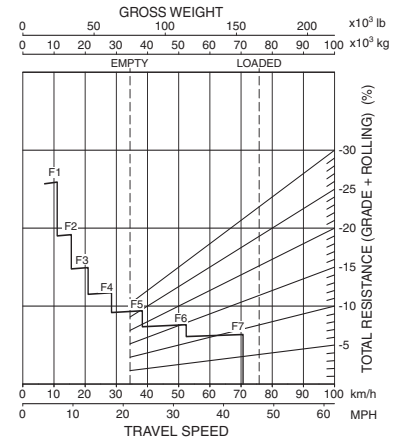

Grade distance: 600 m (1970 ft)

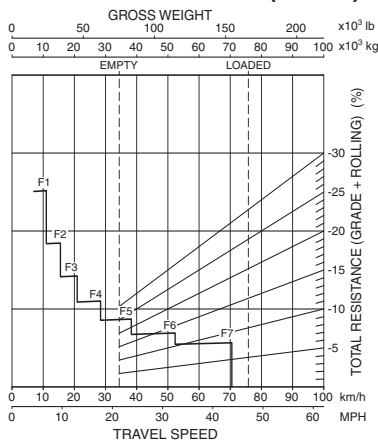

Grade distance: 900 m (2950 ft)

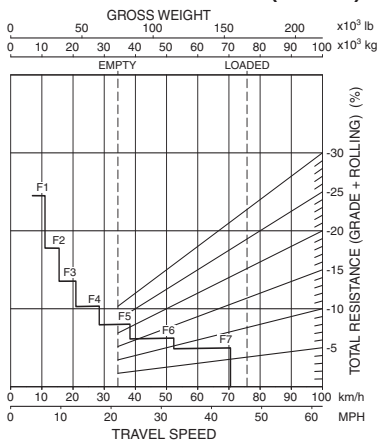

Grade distance: 1500 m (4920 ft)

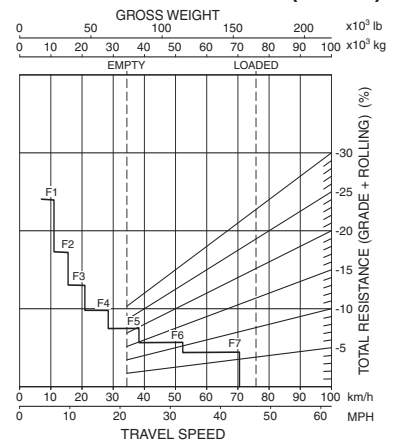



## STANDARD EQUIPMENT

### ENGINE:

- Automatic Idling Setting System (AISS)
- Alternator, 75A/24V
- Batteries, 2 x 12V/170Ah
- Engine, Komatsu SAA6D140E-5
- Starting motor, 1 x 11.0 kW
- Variable horsepower system

### CAB:

- 12V outlet port
- Air conditioner/heater/defroster/ electronically controlled
- Ashtray
- Cigarette lighter
- Cup holder
- Electronic hoist control system
- Electronic maintenance display/monitoring system
- Operator seat, reclining, suspension type with retractable 78 mm 3" width seat belt
- Passenger seat with retractable 78 mm 3" width seat belt
- Power windows (L.H.)

- ROPS cab with FOPS, sound suppression type
- Radio, AM/FM with cassette
- Space for lunch box
- Steering wheel, tilt and telescopic
- Sunvisor
- Tinted glass
- Two doors, left and right
- Windshield washer and wiper (with intermittent feature)

### LIGHTING SYSTEM:

- Back-up light
- Hazard lights
- Headlights with dimmer switch
- Indicator, stop and tail lights

### GUARD AND COVERS:

- Drive shaft guard (front and rear)
- Engine and transmission underguards
- Exhaust thermal guard
- Fire protective covers
- Tire guards

### SAFETY EQUIPMENT:

- Alarm, backup
- Catwalk with hand rails
- Coolant temperature alarm and light
- Front brake cut-off system
- Hand rails for platform
- Horn, electric
- Ladders, left and right hand side
- Overrun warning system
- Rearview mirrors and underview mirrors RH, LH
- Supplementary steering, automatic

### OTHER:

- Electric circuit breaker, 24V
- KOMTRAX
- Side markers



## OPTIONAL EQUIPMENT

### CAB:

- Seat, air suspension

### BODY:

- Spill guard, 150 mm 6" [90 kg 200 lb]
- Quarry body 27.3 m<sup>3</sup> 35.7 yd<sup>3</sup> heaped capacity with 25 mm .99" floor, 14 mm .55" sides and 16 mm .64" front, material is 160 kg/mm<sup>2</sup> 227,500 psi tensile strength and 500 Brinell hardness

### GUARD:

- Platform guard, Right hand side [35 kg 80 lb]

### LIGHTING SYSTEM:

- Fog lights
- Work light, RH and LH side

### TIRES:

- 18.00 R33 tires

### SAFETY:

- Antilock Brake System (ABS)
- Automatic Spin Regulator (ASR)
- Automatic Retard Speed Control (ARSC)

### GAUGE:

- PLM II payload meter

### OTHERS:

- Gas charge tool
- Muffler (no body heating type)
- Fast fuel fill system

Standard equipment may vary for each country. This specification sheet may contain attachments and optional equipment that are not available in your area. Please consult your Komatsu distributor for detailed information.

**KOMATSU**<sup>®</sup>

